

Thermostatic expansion valves Type TD1/TDE1

Contents

Introduction.....	3
Features.....	3
Technical data.....	3
Identification.....	4
Design and function.....	4
Ordering.....	4
R22 capacities:	
SI units.....	5
US units.....	6
R134a capacities:	
SI units.....	7
US units.....	8
R404A capacities:	
SI units.....	9
US units.....	10
Dimensions and weight.....	11

Introduction

TD1/TDE 1 is a thermostatic expansion valve designed to regulate liquid injection into evaporators with smaller capacities in refrigeration, heat pump and air conditioning systems. The liquid injection depends on the refrigerant superheat at the evaporator outlet, where the bulb must be placed.

TD1/TDE 1 is constructed for soldering into hermetic sealed systems and supplied as angleway and straightway version. The product range includes different orifice and connection sizes.

TD1/TDE 1 can be supplied with and without external equalization, with and without MOP and is only available in industrial pack. This technical leaflet contains technical specifications for TD1/TDE 1 valves for R134a, R22 and R404A

Features

- Refrigerants:
R134a, R22 and R404A
Other refrigerants on demand
- Rated capacities from 0.4 to 3.8 kW for R134a (0.11 to 1.1 TR)
- Patented double contact bulb
Fast and easy to install
Good temperature transfer from pipe to bulb
- Supplied with fixed superheat setting as well as adjustable straightway version as tool for setting identification.
- Available with filter at the inlet side
- Version with and without bleed
- Compact and hermetic construction
- Laser welded stainless steel element:
 - optimum regulation properties
 - long life of diaphragm
 - high compressive strength
- Available with universal charge, range N or with MOP charge (MOP 15°C (59°F) and MOP 20°C (68°F))

Technical data

Max. bulb temperature: 120°C (248°F)
 Max. valve housing temperature: 150°C (302°F)
 Max. working pressure PS = 34 bar (500 psig)
 Max. test pressure: p' = 37.5 bar (540 psig)

Equalization connections: 1/4 in. / 6 mm solder ODF
 Capillary tube length: 0.75 m (2.46 Feet)
 Bleed: 15% / 30%

Connections: 1/4 x 3/8 in. / 6 x 10 mm
 Other connections on demand

The rated capacity is based on:
 evaporating temperature $t_0 = 5^\circ\text{C}$
 liquid temperature $t_l = 28^\circ\text{C}$
 condensing temperature $t_c = 32^\circ\text{C}$
 Static superheat = 4K
 Opening superheat = 4K

Type	Rated capacity R134a		Rated capacity R22		Rated capacity R404A	
	Tons TR	kW	Tons TR	kW	Tons TR	kW
TD1/TDE1 0	0.11	0.4	0.15	0.53	0.12	0.42
TD1/TDE1 1	0.23	0.8	0.32	1.1	0.25	0.88
TD1/TDE1 2	0.45	1.6	0.62	2.2	0.5	1.8
TD1/TDE1 3	0.6	2.1	0.83	2.9	0.66	2.3
TD1/TDE1 4	0.9	3.1	1.24	4.34	1.0	3.5
TD1/TDE1 5	1.1	3.8	1.52	5.31	1.21	4.24

Standard and MOP valves

Refrigerant	Range N -40/+10°C (-40/+50°F)	Range K -25/+10°C (-13/+50°F) MOP - point	Range AC -25/+15°C (-13/+59°F) MOP - point
R134a	without MOP	55 psig / 5 bar	70 psig / 5.8 bar
R22	without MOP	100 psig / 7.9 bar	120 psig / 9.3 bar
R404A	without MOP	120 psig / 9.3 bar	140 psig / 10.7 bar

To avoid charge migration when MOP valves are used, the bulb temperature must be lower than the thermostatic element temperature.

Identification

Essential valve data is given on the element label.

Example, fig. 1

- TDN1 / TDEN1 = Type (N: R 134a)
- 0.9 TR = Rated capacity Q_{nom} , in Tons of Refrigeration
- 3.1 kW = Rated capacity Q_{nom} , in kW
- R 134a = Refrigerant
- 25/+10°C = Evaporating temperature range (°C)
- 15/+50°F = Evaporating temperature range (°F)
- 068N1040** = Code number
- BP15 = Bleed 15%
- MOP 60 = Max. Operation Pressure
- PS 34 bar = Max. working pressure
- MWP 500 psig = Max. working pressure
- 184 = Date marking (week **18**, year **2004**)

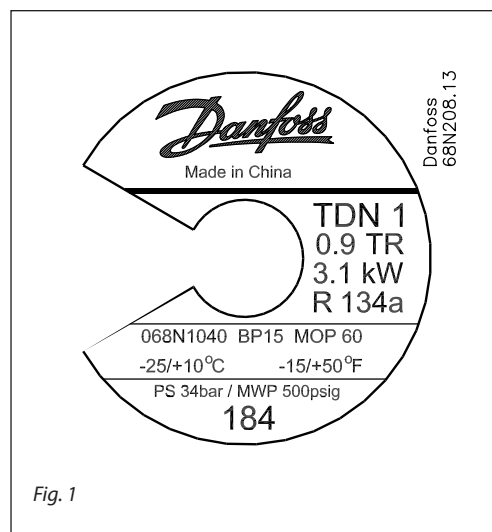

Design and function

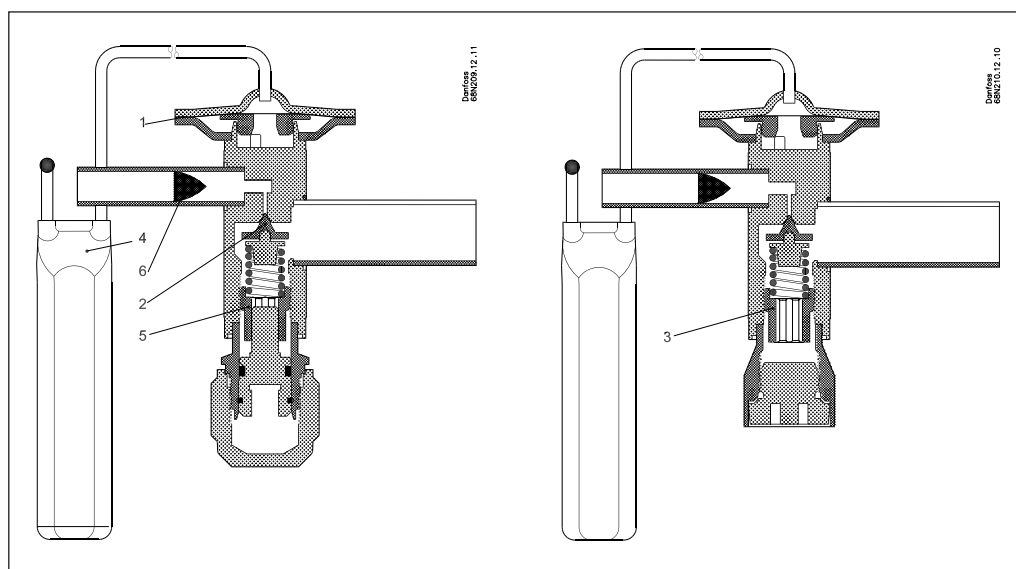

- 1. Thermostatic element (diaphragm)
- 2. Fixed orifice assembly
- 3. Locked setting screw
- 4. Bulb with capillary tube
- 5. Static superheat adjustment
- 6. Strainer

The thermostatic element of the valve has a combination of diaphragm area and charge that in connection with a minimum hysteresis provide the best possible regulation characteristics.

Ordering

As the TD1/TDE1 valve is an OEM valve, a code number programme has not been established.

Code numbers are available on demand.

TD1/TDE1 valves are available in 32-off industrial pack as standard.

Accessories

Buld clips can be delivered separately:

Bulb clip diameter	Code number (Industrial pack - 96 pcs.)
8 mm (5/16 in.)	068N2529
10 mm (3/8 in.)	068N2530
12 mm (1/2 in.)	068N2531

Capacity

SI units

R22

Capacity in kW for range N and K and opening superheat OS = 4 K

Type and rated capacity Q _{nom} TR	Orifice no.	Pressure drop across valve Δp bar								Pressure drop across valve Δp bar							
		2	4	6	8	10	12	14	16	2	4	6	8	10	12	14	16

Evaporating temperature +10°C

Evaporating temperature +5°C

TD/TDE 0.15	0	0.44	0.55	0.61	0.63	0.65	0.66	0.65	0.63	0.44	0.54	0.59	0.62	0.63	0.63	0.62	0.62
TD/TDE 0.32	1	0.88	1.10	1.21	1.27	1.30	1.31	1.30	1.28	0.87	1.08	1.17	1.23	1.26	1.27	1.26	1.24
TD/TDE 0.62	2	1.90	2.25	2.42	2.59	2.59	2.59	2.59	2.59	1.73	2.07	2.42	2.42	2.42	2.42	2.42	2.42
TD/TDE 0.83	3	2.48	2.90	3.31	3.45	3.45	3.45	3.45	3.45	2.21	2.76	3.04	3.17	3.17	3.17	3.17	3.17
TD/TDE 1.24	4	3.73	4.55	4.97	5.11	5.24	5.24	5.24	5.11	3.45	4.14	4.55	4.83	4.83	4.97	4.83	4.69
TD/TDE 1.52	5	4.42	5.52	6.21	6.62	6.76	6.90	6.90	6.76	3.86	4.97	5.66	5.93	6.07	6.07	6.07	6.07

Evaporating temperature 0°C

Evaporating temperature -5°C

TD/TDE 0.15	0	0.43	0.52	0.58	0.59	0.61	0.61	0.61	0.59	0.41	0.51	0.55	0.58	0.58	0.58	0.58	0.57
TD/TDE 0.32	1	0.86	1.05	1.15	1.19	1.21	1.21	1.21	1.19	0.83	1.01	1.09	1.15	1.16	1.16	1.16	1.13
TD/TDE 0.62	2	1.70	2.07	2.25	2.25	2.42	2.42	2.42	2.25	1.56	1.90	2.07	2.25	2.25	2.25	2.25	2.07
TD/TDE 0.83	3	2.07	2.62	2.76	2.90	3.04	3.04	2.90	2.90	1.93	2.35	2.62	2.62	2.76	2.76	2.76	2.62
TD/TDE 1.24	4	3.17	3.08	4.28	4.42	4.55	4.55	4.42	4.42	2.90	3.59	3.86	4.00	4.14	4.14	4.00	4.00
TD/TDE 1.52	5	3.45	4.42	4.97	5.24	5.38	5.38	5.38	5.24	3.17	3.86	4.42	4.55	4.69	4.69	4.69	4.55

Evaporating temperature -10°C

Evaporating temperature -15°C

TD/TDE 0.15	0	0.40	0.48	0.52	0.54	0.55	0.55	0.54	0.54	0.39	0.46	0.50	0.51	0.52	0.52	0.51	0.51
TD/TDE 0.32	1	0.80	0.95	1.04	1.08	1.10	1.10	1.09	1.08	0.76	0.91	0.98	1.02	1.04	1.04	1.02	1.01
TD/TDE 0.62	2	1.53	1.73	1.90	2.07	2.07	2.07	2.07	1.90	1.10	1.32	1.38	1.52	1.52	1.52	1.52	1.52
TD/TDE 0.83	3	1.66	2.62	2.35	2.35	2.48	2.48	2.48	2.35	1.52	1.93	2.07	2.21	2.21	2.21	2.21	2.07
TD/TDE 1.24	4	2.48	3.86	3.45	3.59	3.73	3.73	3.59	3.59	2.21	2.76	3.04	3.17	3.31	3.31	3.17	3.17
TD/TDE 1.52	5	2.76	4.42	3.73	4.00	4.00	4.14	3.59	4.00	2.35	3.04	3.31	3.45	3.45	3.45	3.45	3.31

Evaporating temperature -20°C

Evaporating temperature -25°C

TD/TDE 0.15	0	0.40	0.47	0.52	0.53	0.53	0.53	0.52	0.52	0.36	0.44	0.47	0.49	0.49	0.49	0.49	0.47
TD/TDE 0.32	1	0.78	0.94	1.02	1.05	1.06	1.06	1.05	1.03	0.73	0.87	0.94	0.97	0.99	0.99	0.97	0.94
TD/TDE 0.62	2	1.11	1.34	1.44	1.49	1.50	1.50	1.49	1.44	1.02	1.20	1.29	1.34	1.35	1.35	1.32	1.29
TD/TDE 0.83	3	1.44	1.82	1.98	2.13	2.13	2.13	2.13	1.98	1.25	1.52	1.67	1.82	1.82	1.82	1.82	1.67
TD/TDE 1.24	4	2.13	2.74	2.88	3.04	3.19	3.19	3.04	3.04	1.82	2.28	2.58	2.58	2.58	2.58	2.58	2.58
TD/TDE 1.52	5	2.28	2.74	3.04	3.19	3.19	3.19	3.19	3.04	1.98	2.43	2.58	2.74	2.74	2.74	2.74	2.58

Evaporating temperature -30°C

Evaporating temperature -35°C

TD/TDE 0.15	0	0.33	0.41	0.44	0.46	0.46	0.46	0.44	0.44	0.32	0.36	0.40	0.41	0.41	0.41	0.41	0.40
TD/TDE 0.32	1	0.67	0.81	0.87	0.90	0.91	0.90	0.88	0.87	0.62	0.73	0.79	0.82	0.82	0.82	0.81	0.78
TD/TDE 0.62	2	0.90	1.08	1.16	1.20	1.20	1.20	1.17	1.14	0.76	0.94	1.02	1.05	1.05	1.05	1.02	0.99
TD/TDE 0.83	3	1.06	1.31	1.43	1.49	1.50	1.50	1.47	1.44	0.90	1.09	1.20	1.25	1.25	1.25	1.22	1.19
TD/TDE 1.24	4	1.52	1.98	2.13	2.28	2.28	2.28	2.13	2.13	1.34	1.67	1.82	1.82	1.82	1.82	1.82	1.76
TD/TDE 1.52	5	1.52	1.98	2.13	2.28	2.28	2.28	2.28	2.13	1.37	1.67	1.82	1.82	1.82	1.82	1.82	1.76

Evaporating temperature -40°C

TD/TDE 0.15	0	0.29	0.33	0.36	0.36	0.36	0.36	0.36	0.35
TD/TDE 0.32	1	0.56	0.65	0.71	0.73	0.73	0.73	0.71	0.68
TD/TDE 0.62	2	0.65	0.79	0.85	0.88	0.90	0.88	0.87	0.84
TD/TDE 0.83	3	0.74	0.91	0.99	1.02	1.03	1.02	1.00	0.97
TD/TDE 1.24	4	1.12	1.37	1.47	1.52	1.52	1.52	1.49	1.44
TD/TDE 1.52	5	1.14	1.38	1.50	1.52	1.52	1.52	1.52	1.47

Correction for subcooling Δt_{sub}

The evaporator capacities used must be corrected if subcooling deviates from 4 K.

The corrected capacity can be obtained by dividing the required evaporator capacity by the correction factor below. Selections can then be made from the tables above.

Note:
Insufficient subcooling can produce flash gas.

Δt _{sub}	4 K	10 K	15 K	20 K	25 K	30 K
Correction factor	1.00	1.06	1.11	1.15	1.20	1.25

Capacity (continued)

US units

R22

Capacity in TR for range N and K and opening superheat OS = 7.2°F

Type and rated capacity Q _{nom} TR	Orifice no.	Pressure drop across valve Δp psi								Pressure drop across valve Δp psi							
		29	58	87	116	145	174	203	232	29	58	87	116	145	174	203	232

Evaporating temperature +50°F

Evaporating temperature 41°F

TD/TDE 0.15	0	0.13	0.16	0.17	0.18	0.19	0.19	0.18	0.13	0.15	0.17	0.18	0.18	0.18	0.18	0.18	0.18
TD/TDE 0.32	1	0.25	0.32	0.35	0.36	0.37	0.37	0.37	0.25	0.31	0.34	0.35	0.36	0.36	0.36	0.35	
TD/TDE 0.62	2	0.54	0.64	0.69	0.74	0.74	0.74	0.74	0.49	0.59	0.69	0.69	0.69	0.69	0.69	0.69	
TD/TDE 0.83	3	0.71	0.83	0.95	0.99	0.99	0.99	0.99	0.63	0.79	0.87	0.91	0.91	0.91	0.91	0.91	
TD/TDE 1.24	4	1.06	1.30	1.42	1.46	1.50	1.50	1.50	1.46	0.99	1.18	1.30	1.38	1.38	1.42	1.38	1.34
TD/TDE 1.52	5	1.26	1.58	1.77	1.89	1.93	1.97	1.97	1.93	1.10	1.42	1.62	1.70	1.73	1.73	1.73	1.73

Evaporating temperature 32°F

Evaporating temperature 23°F

TD/TDE 0.15	0	0.12	0.15	0.17	0.17	0.17	0.17	0.17	0.12	0.15	0.16	0.17	0.17	0.17	0.17	0.16	
TD/TDE 0.32	1	0.24	0.30	0.33	0.34	0.35	0.35	0.35	0.24	0.29	0.31	0.33	0.33	0.33	0.33	0.32	
TD/TDE 0.62	2	0.48	0.59	0.64	0.64	0.69	0.69	0.69	0.45	0.54	0.59	0.64	0.64	0.64	0.64	0.59	
TD/TDE 0.83	3	0.59	0.75	0.79	0.83	0.87	0.87	0.83	0.55	0.67	0.75	0.75	0.79	0.79	0.79	0.75	
TD/TDE 1.24	4	0.91	0.88	1.22	1.26	1.30	1.30	1.26	1.26	0.83	1.03	1.10	1.14	1.18	1.18	1.14	1.14
TD/TDE 1.52	5	0.99	1.26	1.42	1.50	1.54	1.54	1.54	1.50	0.91	1.10	1.26	1.30	1.34	1.34	1.34	1.30

Evaporating temperature 14°F

Evaporating temperature 5°F

TD/TDE 0.15	0	0.11	0.14	0.15	0.15	0.16	0.16	0.15	0.15	0.11	0.13	0.14	0.15	0.15	0.15	0.15	
TD/TDE 0.32	1	0.23	0.27	0.30	0.31	0.32	0.32	0.31	0.31	0.22	0.26	0.28	0.29	0.30	0.30	0.29	
TD/TDE 0.62	2	0.44	0.49	0.54	0.59	0.59	0.59	0.59	0.54	0.32	0.38	0.39	0.43	0.43	0.43	0.43	
TD/TDE 0.83	3	0.47	0.75	0.67	0.67	0.71	0.71	0.71	0.67	0.43	0.55	0.59	0.63	0.63	0.63	0.59	
TD/TDE 1.24	4	0.71	1.10	0.99	1.03	1.06	1.06	1.03	1.03	0.63	0.79	0.87	0.91	0.95	0.95	0.91	0.91
TD/TDE 1.52	5	0.79	1.26	1.06	1.14	1.14	1.18	1.03	1.14	0.67	0.87	0.95	0.99	0.99	0.99	0.99	0.95

Evaporating temperature -4°F

Evaporating temperature -13°F

TD/TDE 0.15	0	0.11	0.13	0.15	0.15	0.15	0.15	0.15	0.10	0.13	0.13	0.14	0.14	0.14	0.14	0.13
TD/TDE 0.32	1	0.22	0.27	0.29	0.30	0.30	0.30	0.30	0.21	0.25	0.27	0.28	0.28	0.28	0.28	0.27
TD/TDE 0.62	2	0.32	0.38	0.41	0.43	0.43	0.43	0.43	0.29	0.34	0.37	0.38	0.39	0.39	0.38	0.37
TD/TDE 0.83	3	0.41	0.52	0.56	0.61	0.61	0.61	0.61	0.56	0.36	0.43	0.48	0.52	0.52	0.52	0.48
TD/TDE 1.24	4	0.61	0.78	0.82	0.87	0.91	0.91	0.87	0.87	0.52	0.65	0.74	0.74	0.74	0.74	0.74
TD/TDE 1.52	5	0.65	0.78	0.87	0.91	0.91	0.91	0.91	0.87	0.56	0.69	0.74	0.78	0.78	0.78	0.74

Evaporating temperature -22°F

Evaporating temperature -31°F

TD/TDE 0.15	0	0.10	0.12	0.13	0.13	0.13	0.13	0.13	0.09	0.10	0.11	0.12	0.12	0.12	0.12	0.11
TD/TDE 0.32	1	0.19	0.23	0.25	0.26	0.26	0.26	0.25	0.18	0.21	0.23	0.23	0.23	0.23	0.23	0.22
TD/TDE 0.62	2	0.26	0.31	0.33	0.34	0.34	0.34	0.33	0.22	0.27	0.29	0.30	0.30	0.30	0.29	0.28
TD/TDE 0.83	3	0.30	0.37	0.41	0.43	0.43	0.43	0.42	0.26	0.31	0.34	0.36	0.36	0.36	0.35	0.34
TD/TDE 1.24	4	0.43	0.56	0.61	0.65	0.65	0.65	0.61	0.61	0.38	0.48	0.52	0.52	0.52	0.52	0.50
TD/TDE 1.52	5	0.43	0.56	0.61	0.65	0.65	0.65	0.65	0.61	0.39	0.48	0.52	0.52	0.52	0.52	0.50

Evaporating temperature -40°F

TD/TDE 0.15	0	0.08	0.10	0.10	0.10	0.10	0.10	0.10	0.10
TD/TDE 0.32	1	0.16	0.19	0.20	0.21	0.21	0.21	0.20	0.20
TD/TDE 0.62	2	0.19	0.23	0.24	0.25	0.26	0.25	0.25	0.24
TD/TDE 0.83	3	0.21	0.26	0.28	0.29	0.30	0.29	0.29	0.28
TD/TDE 1.24	4	0.32	0.39	0.42	0.43	0.43	0.43	0.43	0.41
TD/TDE 1.52	5	0.33	0.40	0.43	0.43	0.43	0.43	0.43	0.42

Correction for subcooling Δt_{sub}

The evaporator capacities used must be corrected if subcooling deviates from 7.2°F.

The corrected capacity can be obtained by dividing the required evaporator capacity by the correction factor below. Selections can then be made from the tables above.

Note:
Insufficient subcooling can produce flash gas.

Δt _{sub}	7.2°F	18°F	27°F	36°F	45°F	54°F
Correction factor	1.00	1.06	1.11	1.15	1.20	1.25

Capacity (continued)

SI units

R134a

Capacity in kW for range N and K and opening superheat OS = 4 K

Type and rated capacity Q _{nom} TR	Orifice no.	Pressure drop across valve Δp bar								Pressure drop across valve Δp bar							
		2	4	6	8	10	12	14	16	2	4	6	8	10	12	14	16

Evaporating temperature +10°C

Evaporating temperature +5°C

TD/TDE 0.11	0	0.32	0.40	0.44	0.46	0.47	0.48	0.47	0.46	0.32	0.39	0.43	0.45	0.46	0.46	0.46	0.45
TD/TDE 0.23	1	0.64	0.80	0.88	0.92	0.94	0.95	0.94	0.93	0.63	0.78	0.85	0.89	0.91	0.92	0.91	0.90
TD/TDE 0.45	2	1.38	1.63	1.75	1.88	1.88	1.88	1.88	1.88	1.25	1.50	1.75	1.75	1.75	1.75	1.75	1.75
TD/TDE 0.6	3	1.80	2.10	2.40	2.50	2.50	2.50	2.50	2.50	1.60	2.00	2.20	2.30	2.30	2.30	2.30	2.30
TD/TDE 0.9	4	2.70	3.30	3.60	3.70	3.80	3.80	3.80	3.70	2.50	3.00	3.30	3.50	3.50	3.60	3.50	3.40
TD/TDE 1.1	5	3.20	4.00	4.50	4.80	4.90	5.00	5.00	4.90	2.80	3.60	4.10	4.30	4.40	4.40	4.40	4.40

Evaporating temperature 0°C

Evaporating temperature -5°C

TD/TDE 0.11	0	0.31	0.38	0.42	0.43	0.44	0.44	0.44	0.43	0.30	0.37	0.40	0.42	0.42	0.42	0.42	0.41
TD/TDE 0.23	1	0.62	0.76	0.83	0.86	0.88	0.88	0.88	0.86	0.60	0.73	0.79	0.83	0.84	0.84	0.84	0.82
TD/TDE 0.45	2	1.23	1.50	1.63	1.63	1.75	1.75	1.75	1.63	1.13	1.38	1.50	1.63	1.63	1.63	1.63	1.50
TD/TDE 0.6	3	1.50	1.90	2.00	2.10	2.20	2.20	2.10	2.10	1.40	1.70	1.90	1.90	2.00	2.00	2.00	1.90
TD/TDE 0.9	4	2.30	2.80	3.10	3.20	3.30	3.30	3.20	3.20	2.10	2.60	2.80	2.90	3.00	3.00	2.90	2.90
TD/TDE 1.1	5	2.50	3.20	3.60	3.80	3.90	3.90	3.90	3.80	2.30	2.80	3.20	3.30	3.40	3.40	3.40	3.30

Evaporating temperature -10°C

Evaporating temperature -15°C

TD/TDE 0.11	0	0.29	0.35	0.38	0.39	0.40	0.40	0.39	0.39	0.28	0.33	0.36	0.37	0.38	0.38	0.37	0.37
TD/TDE 0.23	1	0.58	0.69	0.75	0.78	0.80	0.80	0.79	0.78	0.55	0.66	0.71	0.74	0.75	0.75	0.74	0.73
TD/TDE 0.45	2	1.11	1.25	1.38	1.50	1.50	1.50	1.50	1.38	0.80	0.96	1.00	1.10	1.10	1.10	1.10	1.10
TD/TDE 0.6	3	1.20	1.90	1.70	1.70	1.80	1.80	1.80	1.70	1.10	1.40	1.50	1.60	1.60	1.60	1.60	1.50
TD/TDE 0.9	4	1.80	2.80	2.50	2.60	2.70	2.70	2.60	2.60	1.60	2.00	2.20	2.30	2.40	2.40	2.30	2.30
TD/TDE 1.1	5	2.00	3.20	2.70	2.90	2.90	3.00	2.90	2.90	1.70	2.20	2.40	2.50	2.50	2.50	2.50	2.40

Evaporating temperature -20°C

Evaporating temperature -25°C

TD/TDE 0.11	0	0.26	0.31	0.34	0.35	0.35	0.35	0.35	0.34	0.24	0.29	0.31	0.32	0.32	0.32	0.32	0.31
TD/TDE 0.23	1	0.51	0.62	0.67	0.69	0.70	0.70	0.69	0.68	0.48	0.57	0.62	0.64	0.65	0.65	0.64	0.62
TD/TDE 0.45	2	0.73	0.88	0.95	0.98	0.99	0.99	0.98	0.95	0.67	0.79	0.85	0.88	0.89	0.89	0.87	0.85
TD/TDE 0.6	3	0.95	1.20	1.30	1.40	1.40	1.40	1.40	1.30	0.82	1.00	1.10	1.20	1.20	1.20	1.20	1.10
TD/TDE 0.9	4	1.40	1.80	1.90	2.00	2.10	2.10	2.00	2.00	1.20	1.50	1.70	1.70	1.70	1.70	1.70	1.70
TD/TDE 1.1	5	1.50	1.80	2.00	2.10	2.10	2.10	2.10	2.00	1.30	1.60	1.70	1.80	1.80	1.80	1.80	1.70

Evaporating temperature -30°C

Evaporating temperature -35°C

TD/TDE 0.11	0	0.22	0.27	0.29	0.30	0.30	0.30	0.29	0.29	0.21	0.24	0.26	0.27	0.27	0.27	0.27	0.26
TD/TDE 0.23	1	0.44	0.53	0.57	0.59	0.60	0.59	0.58	0.57	0.41	0.48	0.52	0.54	0.54	0.54	0.53	0.51
TD/TDE 0.45	2	0.59	0.71	0.76	0.79	0.79	0.79	0.77	0.75	0.50	0.62	0.67	0.69	0.69	0.69	0.67	0.65
TD/TDE 0.6	3	0.70	0.86	0.94	0.98	0.99	0.99	0.97	0.95	0.59	0.72	0.79	0.82	0.82	0.82	0.80	0.78
TD/TDE 0.9	4	1.00	1.30	1.40	1.50	1.50	1.50	1.40	1.40	0.88	1.10	1.20	1.20	1.20	1.20	1.20	1.16
TD/TDE 1.1	5	1.00	1.30	1.40	1.50	1.50	1.50	1.50	1.40	0.90	1.10	1.20	1.20	1.20	1.20	1.20	1.16

Evaporating temperature -40°C

TD/TDE 0.11	0	0.19	0.22	0.24	0.24	0.24	0.24	0.24	0.23
TD/TDE 0.23	1	0.37	0.43	0.47	0.48	0.48	0.48	0.47	0.45
TD/TDE 0.45	2	0.43	0.52	0.56	0.58	0.59	0.58	0.57	0.55
TD/TDE 0.6	3	0.49	0.60	0.65	0.67	0.68	0.67	0.66	0.64
TD/TDE 0.9	4	0.74	0.90	0.97	1.00	1.00	1.00	0.98	0.95
TD/TDE 1.1	5	0.75	0.91	0.99	1.00	1.00	1.00	1.00	0.97

Correction for subcooling Δt_{sub}

The evaporator capacities used must be corrected if subcooling deviates from 4 K.

The corrected capacity can be obtained by dividing the required evaporator capacity by the correction factor below. Selections can then be made from the tables above.

Note:
Insufficient subcooling can produce flash gas.

Δt _{sub}	4 K	10 K	15 K	20 K	25 K	30 K
Correction factor	1.00	1.08	1.13	1.19	1.25	1.31

Capacity (continued)

US units

R134a

Capacity in TR for range N and K and opening superheat OS = 7.2°F

Type and rated capacity Q _{nom} TR	Orifice no.	Pressure drop across valve Δp bar								Pressure drop across valve Δp bar							
		29	58	87	116	145	174	203	232	29	58	87	116	145	174	203	232

Evaporating temperature +50°F

Evaporating temperature +41°F

TD/TDE 0.11	0	0.09	0.11	0.13	0.13	0.13	0.14	0.13	0.13	0.09	0.11	0.12	0.13	0.13	0.13	0.13	0.13
TD/TDE 0.23	1	0.18	0.23	0.25	0.26	0.27	0.27	0.27	0.27	0.18	0.22	0.24	0.25	0.26	0.26	0.26	0.26
TD/TDE 0.45	2	0.39	0.47	0.50	0.54	0.54	0.54	0.54	0.54	0.36	0.43	0.50	0.50	0.50	0.50	0.50	0.50
TD/TDE 0.6	3	0.51	0.60	0.69	0.71	0.71	0.71	0.71	0.71	0.46	0.57	0.63	0.66	0.66	0.66	0.66	0.66
TD/TDE 0.9	4	0.77	0.94	1.03	1.06	1.09	1.09	1.09	1.06	0.71	0.86	0.94	1.00	1.00	1.03	1.00	0.97
TD/TDE 1.1	5	0.91	1.14	1.29	1.37	1.40	1.43	1.43	1.40	0.80	1.03	1.17	1.23	1.26	1.26	1.26	1.26

Evaporating temperature +32°F

Evaporating temperature +23°F

TD/TDE 0.11	0	0.09	0.11	0.12	0.12	0.13	0.13	0.13	0.12	0.09	0.11	0.11	0.12	0.12	0.12	0.12	0.12
TD/TDE 0.23	1	0.18	0.22	0.24	0.25	0.25	0.25	0.25	0.25	0.17	0.21	0.23	0.24	0.24	0.24	0.24	0.23
TD/TDE 0.45	2	0.35	0.43	0.47	0.47	0.50	0.50	0.50	0.47	0.32	0.39	0.43	0.47	0.47	0.47	0.47	0.43
TD/TDE 0.6	3	0.43	0.54	0.57	0.60	0.63	0.63	0.60	0.60	0.40	0.49	0.54	0.54	0.57	0.57	0.57	0.54
TD/TDE 0.9	4	0.66	0.80	0.89	0.91	0.94	0.94	0.91	0.91	0.60	0.74	0.80	0.83	0.86	0.86	0.83	0.83
TD/TDE 1.1	5	0.71	0.91	1.03	1.09	1.11	1.11	1.11	1.09	0.66	0.80	0.91	0.94	0.97	0.97	0.97	0.94

Evaporating temperature +14°F

Evaporating temperature +5°F

TD/TDE 0.11	0	0.08	0.10	0.11	0.11	0.11	0.11	0.11	0.11	0.08	0.09	0.10	0.11	0.11	0.11	0.11	0.11
TD/TDE 0.23	1	0.17	0.20	0.21	0.22	0.23	0.23	0.23	0.22	0.16	0.19	0.20	0.21	0.21	0.21	0.21	0.21
TD/TDE 0.45	2	0.32	0.36	0.39	0.43	0.43	0.43	0.43	0.39	0.23	0.27	0.29	0.31	0.31	0.31	0.31	0.31
TD/TDE 0.6	3	0.34	0.54	0.49	0.49	0.51	0.51	0.51	0.49	0.31	0.40	0.43	0.46	0.46	0.46	0.46	0.43
TD/TDE 0.9	4	0.51	0.80	0.71	0.74	0.77	0.77	0.74	0.74	0.46	0.57	0.63	0.66	0.69	0.69	0.66	0.66
TD/TDE 1.1	5	0.57	0.91	0.77	0.83	0.83	0.86	0.83	0.83	0.49	0.63	0.69	0.71	0.71	0.71	0.71	0.69

Evaporating temperature -4°F

Evaporating temperature -13°F

TD/TDE 0.11	0	0.07	0.09	0.10	0.10	0.10	0.10	0.10	0.10	0.07	0.08	0.09	0.09	0.09	0.09	0.09	0.09
TD/TDE 0.23	1	0.15	0.18	0.19	0.20	0.20	0.20	0.20	0.19	0.14	0.16	0.18	0.18	0.19	0.19	0.18	0.18
TD/TDE 0.45	2	0.21	0.25	0.27	0.28	0.28	0.28	0.28	0.27	0.19	0.23	0.24	0.25	0.25	0.25	0.25	0.24
TD/TDE 0.6	3	0.27	0.34	0.37	0.40	0.40	0.40	0.40	0.37	0.23	0.29	0.31	0.34	0.34	0.34	0.34	0.31
TD/TDE 0.9	4	0.40	0.51	0.54	0.57	0.60	0.60	0.57	0.57	0.34	0.43	0.49	0.49	0.49	0.49	0.49	0.49
TD/TDE 1.1	5	0.43	0.51	0.57	0.60	0.60	0.60	0.60	0.57	0.37	0.46	0.49	0.51	0.51	0.51	0.51	0.49

Evaporating temperature -22°F

Evaporating temperature -31°F

TD/TDE 0.11	0	0.06	0.08	0.08	0.09	0.09	0.09	0.08	0.08	0.06	0.07	0.07	0.08	0.08	0.08	0.08	0.07
TD/TDE 0.23	1	0.13	0.15	0.16	0.17	0.17	0.17	0.17	0.16	0.12	0.14	0.15	0.15	0.15	0.15	0.15	0.15
TD/TDE 0.45	2	0.17	0.20	0.22	0.23	0.23	0.23	0.22	0.21	0.14	0.18	0.19	0.20	0.20	0.20	0.19	0.19
TD/TDE 0.6	3	0.20	0.25	0.27	0.28	0.28	0.28	0.28	0.27	0.17	0.21	0.23	0.23	0.23	0.23	0.23	0.22
TD/TDE 0.9	4	0.29	0.37	0.40	0.43	0.43	0.43	0.40	0.40	0.25	0.31	0.34	0.34	0.34	0.34	0.34	0.33
TD/TDE 1.1	5	0.29	0.37	0.40	0.43	0.43	0.43	0.43	0.40	0.26	0.31	0.34	0.34	0.34	0.34	0.34	0.33

Evaporating temperature -40°F

TD/TDE 0.11	0	0.05	0.06	0.07	0.07	0.07	0.07	0.07	0.07
TD/TDE 0.23	1	0.11	0.12	0.13	0.14	0.14	0.14	0.13	0.13
TD/TDE 0.45	2	0.12	0.15	0.16	0.17	0.17	0.17	0.16	0.16
TD/TDE 0.6	3	0.14	0.17	0.19	0.19	0.19	0.19	0.19	0.18
TD/TDE 0.9	4	0.21	0.26	0.28	0.29	0.29	0.29	0.28	0.27
TD/TDE 1.1	5	0.21	0.26	0.28	0.29	0.29	0.29	0.29	0.28

Correction for subcooling Δt_{sub}

The evaporator capacities used must be corrected if subcooling deviates from 7.2°F.

The corrected capacity can be obtained by dividing the required evaporator capacity by the correction factor below. Selections can then be made from the tables above.

Note:
Insufficient subcooling can produce flash gas.

Δt _{sub}	7.2°F	18°F	27°F	36°F	45°F	54°F
Correction factor	1.00	1.08	1.13	1.19	1.25	1.31

Capacity (continued)

SI units

R404A

Capacity in kW for range N and K and opening superheat OS = 4 K

Type and rated capacity Q _{nom} TR	Orifice no.	Pressure drop across valve Δp bar								Pressure drop across valve Δp bar							
		2	4	6	8	10	12	14	16	2	4	6	8	10	12	14	16

Evaporating temperature +10°C

Evaporating temperature +5°C

TD/TDE 0.12	0	0.35	0.44	0.48	0.51	0.52	0.53	0.52	0.51	0.35	0.43	0.47	0.50	0.51	0.51	0.51	0.50
TD/TDE 0.25	1	0.70	0.88	0.97	1.01	1.03	1.05	1.03	1.02	0.69	0.86	0.94	0.98	1.00	1.01	1.00	0.99
TD/TDE 0.5	2	1.52	1.79	1.93	2.07	2.07	2.07	2.04	2.07	1.38	1.65	1.93	1.93	1.93	1.93	1.93	1.93
TD/TDE 0.66	3	1.98	2.31	2.64	2.75	2.75	2.75	2.75	2.75	1.76	2.20	2.42	2.53	2.53	2.53	2.53	2.53
TD/TDE 1.0	4	2.97	3.63	3.96	4.07	4.18	4.18	4.18	4.07	2.75	3.30	3.63	3.85	3.85	3.96	3.85	3.74
TD/TDE 1.21	5	3.52	4.40	4.95	5.28	5.39	5.50	5.50	5.39	3.08	3.96	4.51	4.73	4.84	4.84	4.84	4.84

Evaporating temperature 0°C

Evaporating temperature -5°C

TD/TDE 0.12	0	0.34	0.42	0.46	0.47	0.48	0.48	0.48	0.47	0.33	0.41	0.44	0.46	0.46	0.46	0.46	0.45
TD/TDE 0.25	1	0.68	0.84	0.81	0.95	0.97	0.97	0.97	0.95	0.66	0.80	0.87	0.91	0.92	0.92	0.92	0.90
TD/TDE 0.5	2	1.35	1.65	1.79	1.76	1.93	1.93	1.93	1.79	1.24	1.52	1.65	1.79	1.79	1.79	1.79	1.65
TD/TDE 0.66	3	1.65	2.09	2.20	2.31	2.42	2.42	2.31	2.31	1.54	1.87	2.09	2.09	2.20	2.20	2.20	2.09
TD/TDE 1.0	4	2.53	3.08	3.41	3.52	3.63	3.63	3.52	3.52	2.31	2.86	3.08	3.19	3.30	3.30	3.19	3.19
TD/TDE 1.21	5	2.75	3.52	3.96	4.18	4.29	4.29	4.29	4.18	2.53	3.08	3.52	3.63	3.74	3.74	3.74	3.63

Evaporating temperature -10°C

Evaporating temperature -15°C

TD/TDE 0.12	0	0.32	0.39	0.42	0.43	0.44	0.44	0.43	0.43	0.31	0.36	0.40	0.41	0.42	0.42	0.41	0.41
TD/TDE 0.25	1	0.64	0.76	0.83	0.86	0.88	0.88	0.87	0.86	0.61	0.73	0.78	0.81	0.83	0.83	0.81	0.80
TD/TDE 0.5	2	1.22	1.38	1.52	1.65	1.65	1.65	1.65	1.52	0.88	1.06	1.10	1.21	1.21	1.21	1.21	1.21
TD/TDE 0.66	3	1.32	2.09	1.87	1.87	1.98	1.98	1.98	1.87	1.21	1.54	1.65	1.76	1.76	1.76	1.76	1.65
TD/TDE 1.0	4	1.92	3.08	2.75	2.86	2.97	2.97	2.86	2.86	1.76	2.20	2.42	2.53	2.64	2.64	2.53	2.53
TD/TDE 1.21	5	2.20	3.52	2.97	3.19	3.19	3.30	3.19	3.19	1.97	2.42	2.64	2.75	2.75	2.75	2.75	2.64

Evaporating temperature -20°C

Evaporating temperature -25°C

TD/TDE 0.12	0	0.28	0.33	0.37	0.38	0.38	0.38	0.38	0.37	0.26	0.31	0.33	0.35	0.35	0.35	0.35	0.33
TD/TDE 0.25	1	0.55	0.67	0.72	0.75	0.76	0.76	0.75	0.73	0.52	0.62	0.67	0.69	0.70	0.70	0.69	0.67
TD/TDE 0.5	2	0.79	0.95	1.03	1.06	1.07	1.07	1.06	1.03	0.72	0.85	0.92	0.95	0.96	0.96	0.94	0.92
TD/TDE 0.66	3	1.03	1.30	1.40	1.51	1.51	1.51	1.51	1.40	0.89	1.08	1.19	1.30	1.30	1.30	1.30	1.19
TD/TDE 1.0	4	1.51	1.94	2.05	2.16	2.27	2.27	2.16	2.16	1.30	1.62	1.84	1.84	1.84	1.84	1.84	1.84
TD/TDE 1.21	5	1.62	1.94	2.16	2.27	2.27	2.27	2.27	2.16	1.40	1.73	1.84	1.94	1.94	1.94	1.94	1.84

Evaporating temperature -30°C

Evaporating temperature -35°C

TD/TDE 0.12	0	0.24	0.29	0.31	0.32	0.32	0.32	0.31	0.31	0.23	0.26	0.28	0.29	0.29	0.29	0.29	0.28
TD/TDE 0.25	1	0.48	0.57	0.62	0.64	0.65	0.64	0.63	0.62	0.44	0.52	0.56	0.58	0.58	0.58	0.57	0.55
TD/TDE 0.5	2	0.64	0.77	0.82	0.85	0.85	0.85	0.83	0.81	0.54	0.67	0.72	0.75	0.75	0.75	0.72	0.70
TD/TDE 0.66	3	0.76	0.93	1.02	1.06	1.07	1.07	1.05	1.03	0.64	0.78	0.85	0.89	0.89	0.89	0.86	0.84
TD/TDE 1.0	4	1.08	1.40	1.51	1.62	1.62	1.62	1.51	1.51	0.95	1.19	1.30	1.30	1.30	1.30	1.30	1.25
TD/TDE 1.21	5	1.08	1.40	1.51	1.62	1.62	1.62	1.51	0.97	1.19	1.30	1.30	1.30	1.30	1.30	1.30	1.25

Evaporating temperature -40°C

TD/TDE 0.12	0	0.21	0.24	0.26	0.26	0.26	0.26	0.26	0.24
TD/TDE 0.25	1	0.40	0.46	0.51	0.52	0.52	0.52	0.51	0.49
TD/TDE 0.5	2	0.46	0.56	0.60	0.63	0.64	0.63	0.62	0.59
TD/TDE 0.66	3	0.53	0.65	0.70	0.72	0.73	0.72	0.71	0.69
TD/TDE 1.0	4	0.80	0.97	1.05	1.08	1.08	1.08	1.06	1.03
TD/TDE 1.21	5	0.81	0.98	1.07	1.08	1.08	1.08	1.08	1.05

Correction for subcooling Δt_{sub}

The evaporator capacities used must be corrected if subcooling deviates from 4 K.

The corrected capacity can be obtained by dividing the required evaporator capacity by the correction factor below. Selections can then be made from the tables above.

Note:
Insufficient subcooling can produce flash gas.

Δt _{sub}	4 K	10 K	15 K	20 K	25 K	30 K
Correction factor	1.00	1.1	1.2	1.29	1.37	1.46

Capacity (continued)

US units

R404A

Capacity in TR for range N and K and opening superheat OS = 7.2°F

Type and rated capacity Q _{nom} TR	Orifice no.	Pressure drop across valve Δp psi								Pressure drop across valve Δp psi							
		29	58	87	116	145	174	203	232	29	58	87	116	145	174	203	232

Evaporating temperature +50°F

Evaporating temperature +41°F

TD/TDE 0.12	0	0.13	0.16	0.17	0.18	0.19	0.19	0.19	0.18	0.13	0.15	0.17	0.18	0.18	0.18	0.18	0.18
TD/TDE 0.25	1	0.25	0.32	0.35	0.36	0.37	0.37	0.37	0.37	0.25	0.31	0.34	0.35	0.36	0.36	0.36	0.35
TD/TDE 0.5	2	0.54	0.64	0.69	0.74	0.74	0.74	0.74	0.74	0.49	0.59	0.69	0.69	0.69	0.69	0.69	0.69
TD/TDE 0.66	3	0.71	0.83	0.95	0.99	0.99	0.99	0.99	0.99	0.63	0.79	0.87	0.91	0.91	0.91	0.91	0.91
TD/TDE 1.0	4	1.06	1.30	1.42	1.46	1.50	1.50	1.50	1.46	0.99	1.18	1.30	1.38	1.38	1.42	1.38	1.34
TD/TDE 1.21	5	1.26	1.58	1.77	1.89	1.93	1.97	1.97	1.93	1.10	1.42	1.62	1.70	1.73	1.73	1.73	1.73

Evaporating temperature +32°F

Evaporating temperature +23°F

TD/TDE 0.12	0	0.12	0.15	0.17	0.17	0.17	0.17	0.17	0.17	0.12	0.15	0.16	0.17	0.17	0.17	0.17	0.16
TD/TDE 0.25	1	0.24	0.30	0.33	0.34	0.35	0.35	0.35	0.34	0.24	0.29	0.31	0.33	0.33	0.33	0.33	0.32
TD/TDE 0.5	2	0.48	0.59	0.64	0.64	0.69	0.69	0.69	0.64	0.45	0.54	0.59	0.64	0.64	0.64	0.64	0.59
TD/TDE 0.66	3	0.59	0.75	0.79	0.83	0.87	0.87	0.83	0.83	0.55	0.67	0.75	0.75	0.79	0.79	0.79	0.75
TD/TDE 1.0	4	0.91	0.88	1.22	1.26	1.30	1.30	1.26	1.26	0.83	1.03	1.10	1.14	1.18	1.18	1.14	1.14
TD/TDE 1.21	5	0.99	1.26	1.42	1.50	1.54	1.54	1.54	1.50	0.91	1.10	1.26	1.30	1.34	1.34	1.34	1.30

Evaporating temperature +14°F

Evaporating temperature +5°F

TD/TDE 0.12	0	0.11	0.14	0.15	0.15	0.16	0.16	0.15	0.15	0.11	0.13	0.14	0.15	0.15	0.15	0.15	0.15
TD/TDE 0.25	1	0.23	0.27	0.30	0.31	0.32	0.32	0.31	0.31	0.22	0.26	0.28	0.29	0.30	0.30	0.29	0.29
TD/TDE 0.5	2	0.44	0.49	0.54	0.59	0.59	0.59	0.59	0.54	0.32	0.38	0.39	0.43	0.43	0.43	0.43	0.43
TD/TDE 0.66	3	0.47	0.75	0.67	0.67	0.71	0.71	0.71	0.67	0.43	0.55	0.59	0.63	0.63	0.63	0.63	0.59
TD/TDE 1.0	4	0.71	1.10	0.99	1.03	1.06	1.06	1.03	1.03	0.63	0.79	0.87	0.91	0.95	0.95	0.91	0.91
TD/TDE 1.21	5	0.79	1.26	1.06	1.14	1.14	1.18	1.03	1.14	0.67	0.87	0.95	0.99	0.99	0.99	0.99	0.95

Evaporating temperature -4°F

Evaporating temperature -13°F

TD/TDE 0.12	0	0.11	0.13	0.15	0.15	0.15	0.15	0.15	0.15	0.10	0.13	0.13	0.14	0.14	0.14	0.14	0.13
TD/TDE 0.25	1	0.22	0.27	0.29	0.30	0.30	0.30	0.30	0.30	0.21	0.25	0.27	0.28	0.28	0.28	0.28	0.27
TD/TDE 0.5	2	0.32	0.38	0.41	0.43	0.43	0.43	0.43	0.41	0.29	0.34	0.37	0.38	0.39	0.39	0.38	0.37
TD/TDE 0.66	3	0.41	0.52	0.56	0.61	0.61	0.61	0.61	0.56	0.36	0.43	0.48	0.52	0.52	0.52	0.52	0.48
TD/TDE 1.0	4	0.61	0.78	0.82	0.87	0.91	0.91	0.87	0.87	0.52	0.65	0.74	0.74	0.74	0.74	0.74	0.74
TD/TDE 1.21	5	0.65	0.78	0.87	0.91	0.91	0.91	0.91	0.87	0.56	0.69	0.74	0.78	0.78	0.78	0.78	0.74

Evaporating temperature -22°F

Evaporating temperature -31°F

TD/TDE 0.12	0	0.10	0.12	0.13	0.13	0.13	0.13	0.13	0.13	0.09	0.10	0.11	0.12	0.12	0.12	0.12	0.11
TD/TDE 0.25	1	0.19	0.23	0.25	0.26	0.26	0.26	0.25	0.25	0.18	0.21	0.23	0.23	0.23	0.23	0.23	0.22
TD/TDE 0.5	2	0.26	0.31	0.33	0.34	0.34	0.34	0.33	0.33	0.22	0.27	0.29	0.30	0.30	0.30	0.29	0.28
TD/TDE 0.66	3	0.30	0.37	0.41	0.43	0.43	0.43	0.42	0.41	0.26	0.31	0.34	0.36	0.36	0.36	0.35	0.34
TD/TDE 1.0	4	0.43	0.56	0.61	0.65	0.65	0.65	0.61	0.61	0.38	0.48	0.52	0.52	0.52	0.52	0.52	0.50
TD/TDE 1.21	5	0.43	0.56	0.61	0.65	0.65	0.65	0.65	0.61	0.39	0.48	0.52	0.52	0.52	0.52	0.52	0.50

Evaporating temperature -40°F

TD/TDE 0.12	0	0.08	0.10	0.10	0.10	0.10	0.10	0.10	0.10
TD/TDE 0.25	1	0.16	0.19	0.20	0.21	0.21	0.21	0.20	0.20
TD/TDE 0.5	2	0.19	0.23	0.24	0.25	0.26	0.25	0.25	0.24
TD/TDE 0.66	3	0.21	0.26	0.28	0.29	0.30	0.29	0.29	0.28
TD/TDE 1.0	4	0.32	0.39	0.42	0.43	0.43	0.43	0.43	0.41
TD/TDE 1.21	5	0.33	0.40	0.43	0.43	0.43	0.43	0.43	0.42

Correction for subcooling Δt_{sub}

The evaporator capacities used must be corrected if subcooling deviates from 7.2°F. The corrected capacity can be obtained by dividing the required evaporator capacity by the correction factor below. Selections can then be made from the tables above.

Note:
Insufficient subcooling can produce flash gas.

Δt _{sub}	7.2°F	18°F	27°F	36°F	45°F	54°F
Correction factor	1.00	1.08	1.13	1.19	1.25	1.31

Dimensions and weight

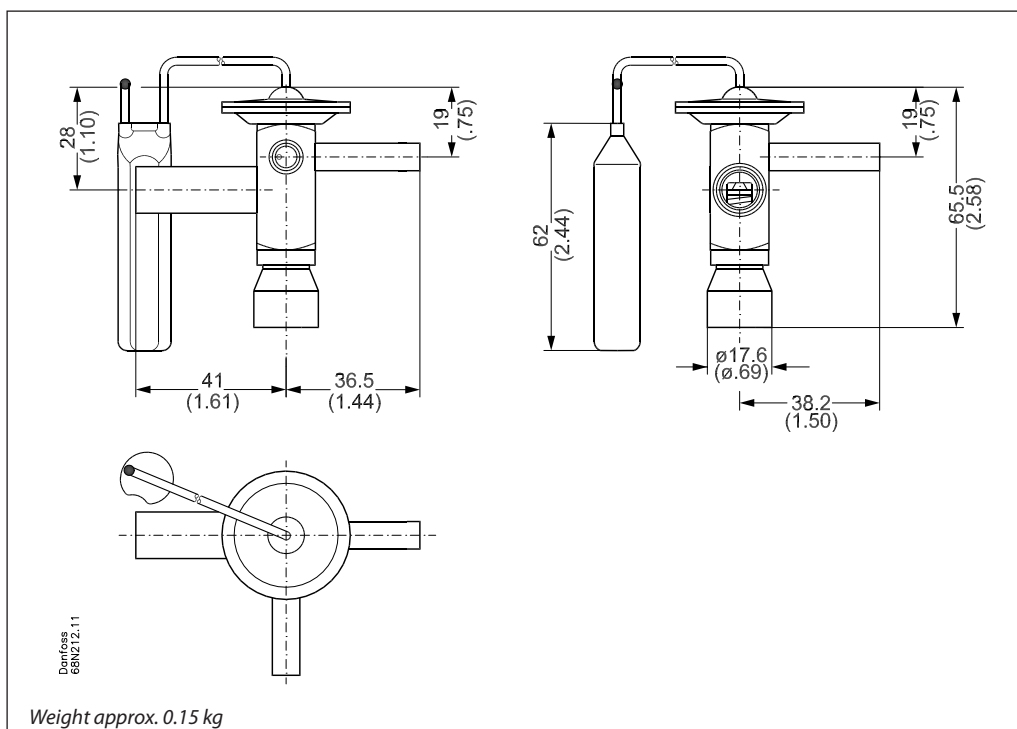
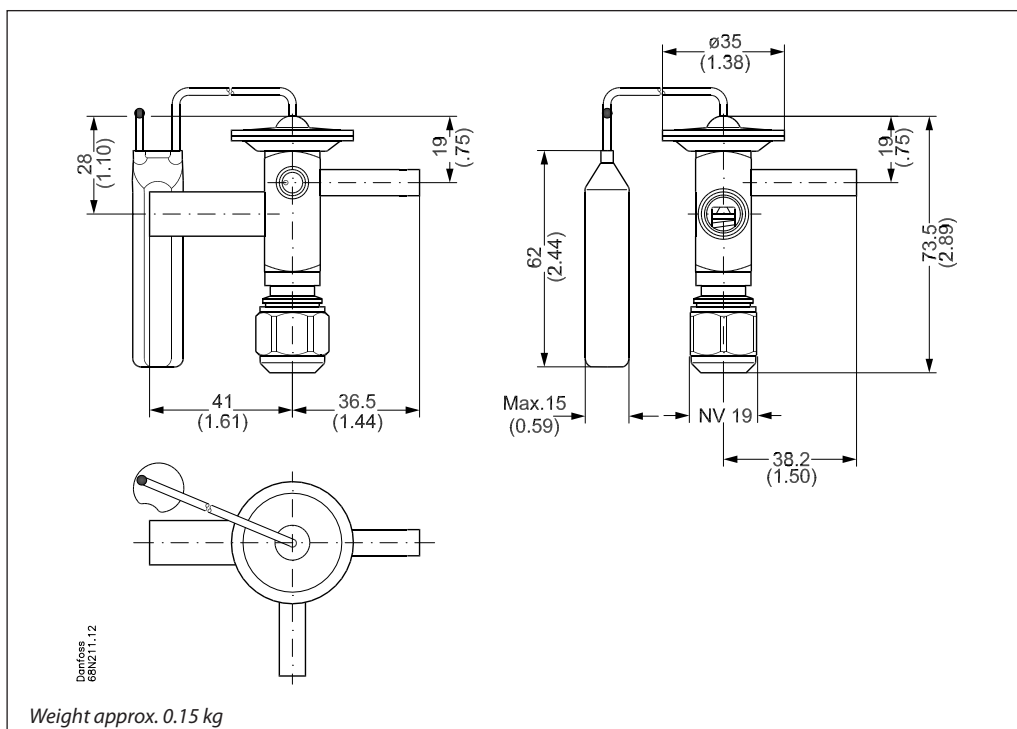

Dimensions and weight

